



Servicing and Tuning Guide

IMPORTANT: Read before Commencing Work

These instructions are intended as a general guide to servicing and tuning the type H carburettor in both single and multi-installations. It is essential, particularly where vehicles are equipped and tuned to comply with engine emission control regulations, that the carburettors are tuned in accordance with the vehicle manufacturer's tuning data.

To achieve the best results when tuning, the use of a reliable tachometer, balancing meter and an exhaust gas analyser are required. **These instruments are essential when tuning vehicles equipped to conform with exhaust emission regulations.**

Before servicing or tuning a carburettor in an endeavour to rectify poor engine performance, make sure that the maladjustment or fault is not from another source by checking the following:

- Valve clearance
- Spark plug condition
- Contact breaker (dwell angle)
- Ignition timing and advance
- Presence of air leaks into the induction system

This Kit contains only Genuine SU Components

Routine Servicing

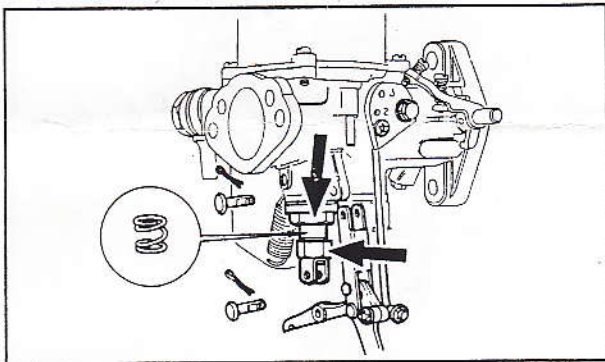

Jet centering

The piston should fall freely onto the carburettor bridge with a click when the lifting pin is released with the jet in the fully up position. If it will only do this with the jet lowered then the jet unit requires re-centring. This is done as follows:

- 1
 - (a) Remove the jet control linkage and swing it to one side.
 - (b) Mark for reassembly and withdraw the jet, remove the jet locking spring, replace the

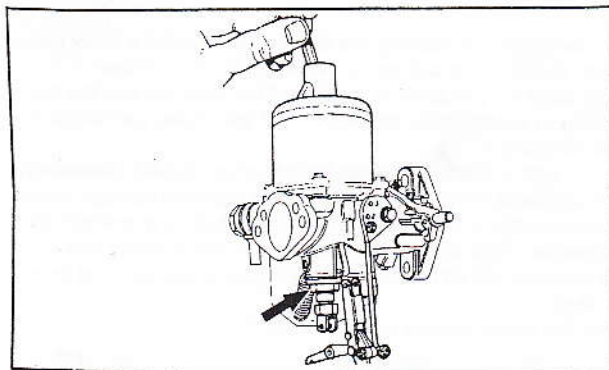

adjusting nut and screw it up as far as it will go.

- (c) Replace the jet, keeping the jet head in the correct relative position to the control lever.
- (d) Slacken the jet locking nut until the assembly is free to rotate.

2

- (a) Remove the piston damper and apply pressure to the top of the piston rod with a pencil.
- (b) Tighten the jet locking nut keeping the jet head in the correct position and the jet hard up against the adjusting nut.
- (c) Finally check the action of the piston again.
- (d) Reassemble the controls.
- (e) Refill the piston dampers with thin engine oil as in tuning section (8).

Cleaning

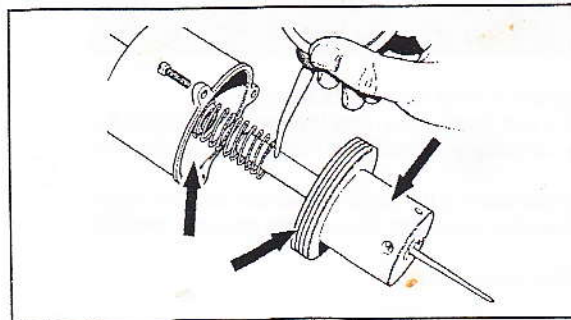

- (a) At the recommended intervals mark for reassembly and carefully remove the piston/suction chamber unit.
- (b) Using a petrol or meths moistened cloth, clean the inside bore of the suction chamber and the two diameters of the piston.
- (c) Lightly oil the piston rod only and reassemble as marked.

H TYPE CARBURETTOR KIT

Float Chamber Fuel Level

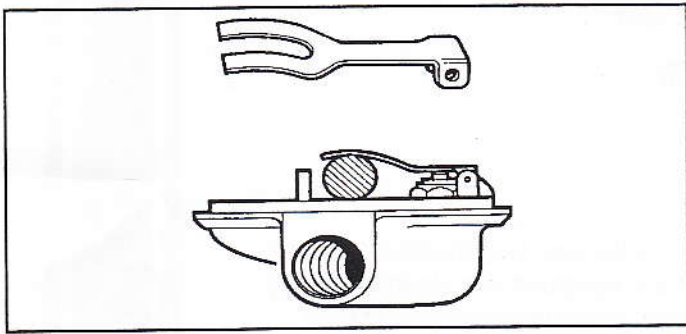

- (a) Remove the float chamber lid and invert it.
- (b) With the needle on its seating insert a 11.0 mm (7/16 in) diameter round bar between the forked lever and the lip of the float chamber lid.
- (c) The prongs of the lever should just rest on the bar. If not, carefully bend the lever until they do.

Needle size and position

The needle size is determined during engine development and will provide the correct mixture strength except when under extremes of temperature, humidity, or altitude; e.g. a weaker needle will be necessary at altitudes exceeding 1800 m (6,000 ft.) If modifications are made to the engine: (e.g. camshaft, compression ratio, air cleaner or exhaust system) a different needle may be necessary to maintain performance.

- (a) To check the needle fitted, remove the piston/suction chamber unit.
- (b) Slacken the needle clamping screw, extract the needle, and check its identifying mark against the recommendation.

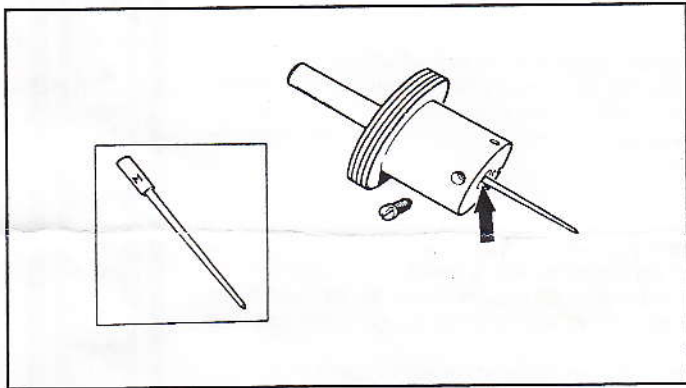

- (c) Fit the correct needle and lock it in position so that the shoulder on the shank is flush with the piston base.
- (d) Reassemble the piston/suction chamber unit.

Dismantling

- 1 Thoroughly clean the outside of the carburettor.
- (b) Remove the banjo bolt, banjo union and fibre washers. Extract the filter and spring assembly from inside the inlet of the float chamber lid.
- (c) Mark the relative positions of the suction chamber and the body.
- (d) Remove the damper and its washer. Unscrew the chamber retaining screws.
- (e) Lift off the chamber without tilting it.

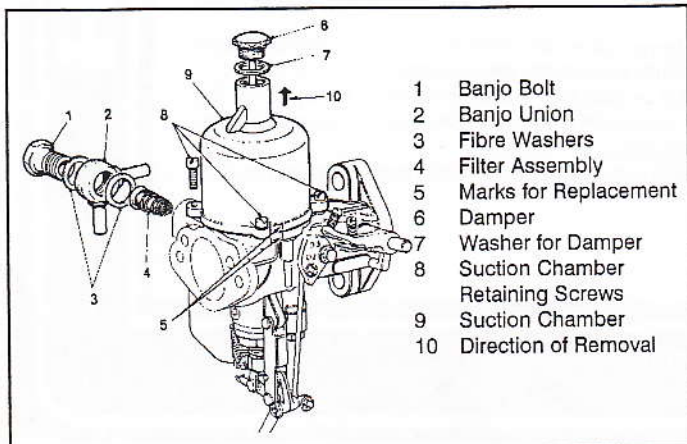

2

- (a) Remove the piston spring and washer (when fitted).
- (b) Carefully lift out the piston assembly and empty the damper oil from the piston rod.
- (c) Remove the needle locking screw and the needle. If the needle cannot be easily removed, first tap it inwards and then pull it out, do not bend it.

3

- (a) Unhook the lever return spring. Remove the split pins and clevis pins.
- (b) Remove the fast-idle cam pivot bolt. Note the positions of the double-coil spring washer and the aluminium spacing washer.
- (c) Detach the linkage assembly.
- (d) Press up the piston lifting pin, extract the circlip from its groove and withdraw the pin and its spring downwards.

4

- (a) Withdraw the jet downwards.
- (b) Detach the jet adjusting nut and spring.
- (c) Unscrew the jet locking nut and withdraw the assembly carefully.
- (d) Lift off the upper jet bearing and copper washer. From inside the bearing extract the gland and brass gland washer.

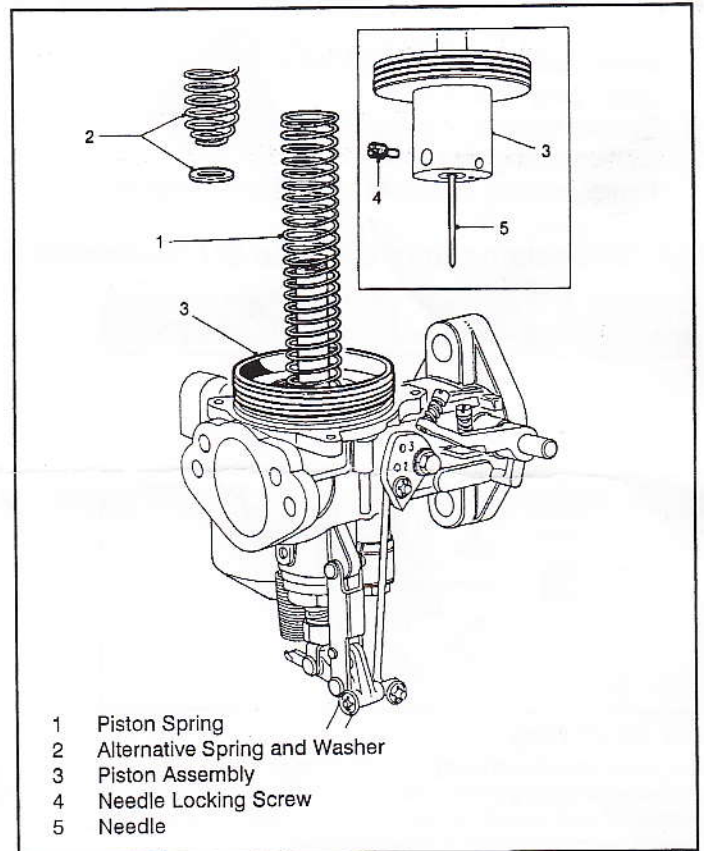

- (e) Remove the gland spring and withdraw the lower jet bearing from the jet locking nut. Note the brass washer under the shoulder of the bearing. Extract the gland and brass gland washer from inside the bearing. Do not disturb the jet locking nut cork washer.

5

- (a) Remove the screw retaining the stay to the carburettor body (when fitted). Remove the bolt or nut retaining the float-chamber to the body. Note the positions of the three fibre washers and the brass washer, or alternatively, the position of the rubber grommets and steel washers.
- (b) Mark the relative position of the float chamber and lid. Unscrew the central nut and remove the drain pipe and washers; the stay, washer and cover cap, or the cover cap alone, as is fitted to the individual carburettor. Note the relative positions of the washers and other components. Lift off the lid, noting the gasket between the lid and the chamber.
- (c) Invert the float-chamber to remove the float.

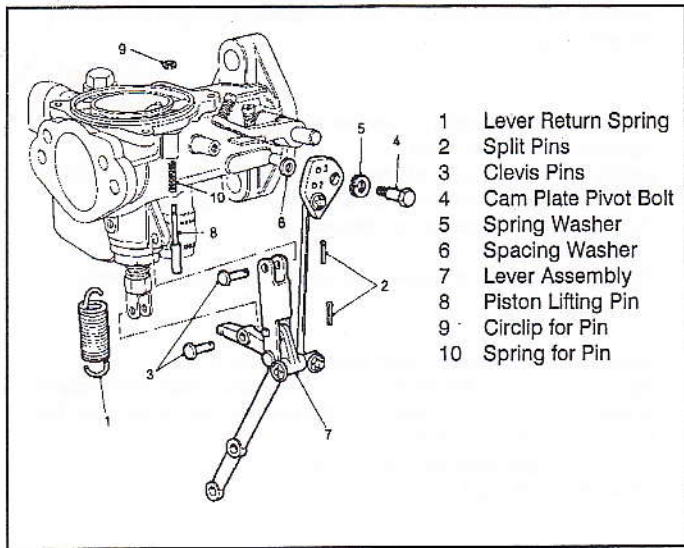

- 1 Lever Return Spring
- 2 Split Pins
- 3 Clevis Pins
- 4 Cam Plate Pivot Bolt
- 5 Spring Washer
- 6 Spacing Washer
- 7 Lever Assembly
- 8 Piston Lifting Pin
- 9 Circlip for Pin
- 10 Spring for Pin

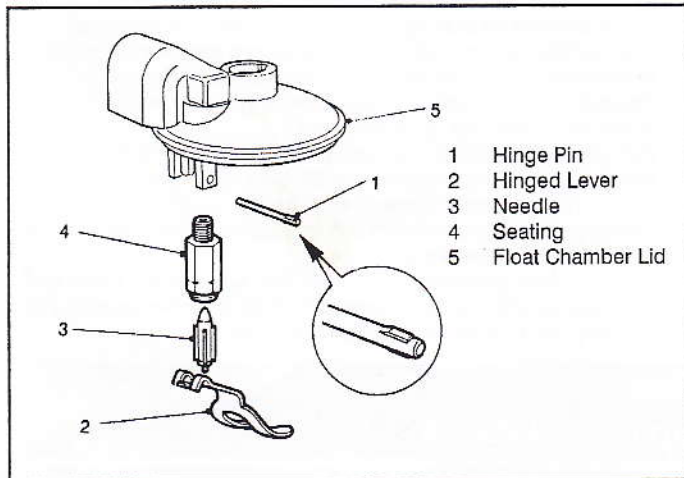

- 1 Hinge Pin
- 2 Hinged Lever
- 3 Needle
- 4 Seating
- 5 Float Chamber Lid

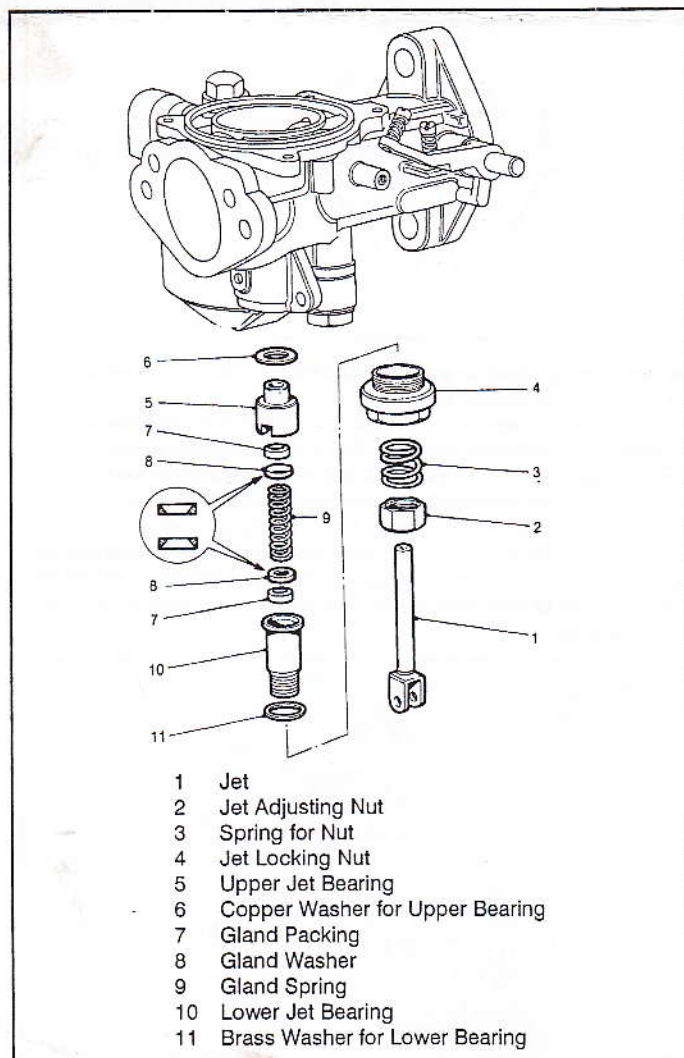

- 1 Jet
- 2 Jet Adjusting Nut
- 3 Spring for Nut
- 4 Jet Locking Nut
- 5 Upper Jet Bearing
- 6 Copper Washer for Upper Bearing
- 7 Gland Packing
- 8 Gland Washer
- 9 Gland Spring
- 10 Lower Jet Bearing
- 11 Brass Washer for Lower Bearing

- 6
 - (a) Push out the hinge pin of the hinged lever from the end opposite to its serrations and detach the lever.
 - (b) Lift out the needle from its seating and unscrew the seating from the lid using a box spanner 8.58 mm (0.338 in) across the flats. Take great care not to distort the seating.
- 7
 - (a) Slacken the spring clip bolt and remove the clip, spring, and return spring plate (when

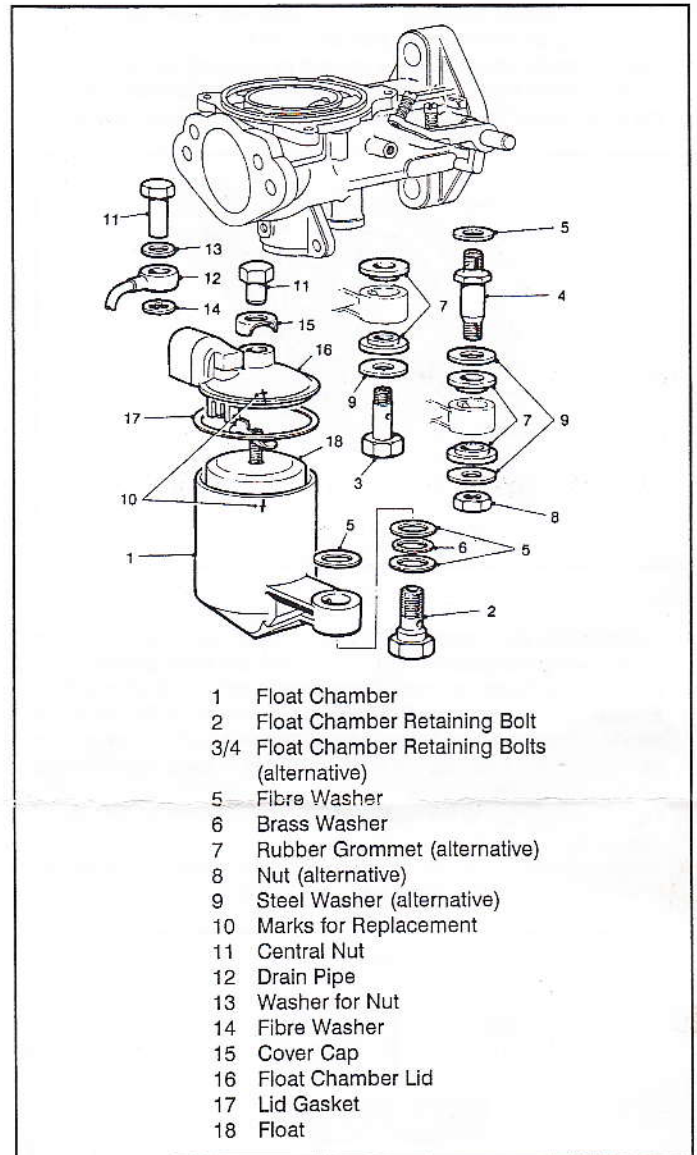

- 1 Float Chamber
- 2 Float Chamber Retaining Bolt
- 3/4 Float Chamber Retaining Bolts (alternative)
- 5 Fibre Washer
- 6 Brass Washer
- 7 Rubber Grommet (alternative)
- 8 Nut (alternative)
- 9 Steel Washer (alternative)
- 10 Marks for Replacement
- 11 Central Nut
- 12 Drain Pipe
- 13 Washer for Nut
- 14 Fibre Washer
- 15 Cover Cap
- 16 Float Chamber Lid
- 17 Lid Gasket
- 18 Float

- (fitted). If a clamp-type operating lever is fitted, slacken the clamping bolt and remove the lever.
- (b) Close the throttle and mark the position of the throttle disc.
- (c) Unscrew the two disc retaining screws.
- (d) Open the throttle and ease out the disc from its slot in the throttle spindle. The disc is oval and will jam if not withdrawn carefully.
- (e) Withdraw the spindle from the carburettor body.

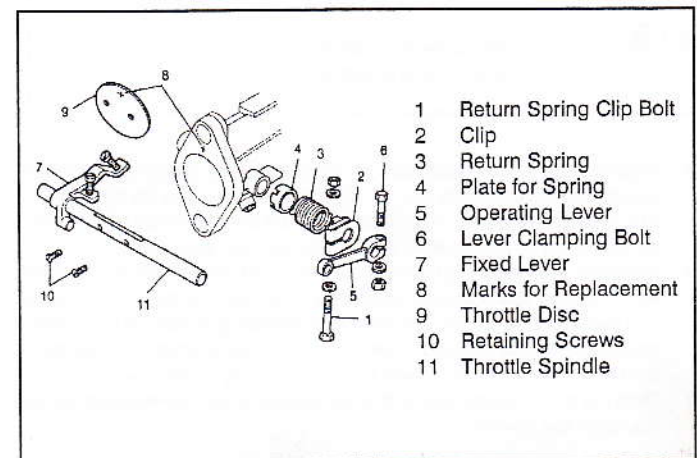

- 1 Return Spring Clip Bolt
- 2 Clip
- 3 Return Spring
- 4 Plate for Spring
- 5 Operating Lever
- 6 Lever Clamping Bolt
- 7 Fixed Lever
- 8 Marks for Replacement
- 9 Throttle Disc
- 10 Retaining Screws
- 11 Throttle Spindle

Reassembly

Before reassembly all components must be examined for damage and/or wear. Unserviceable components must be renewed.

1

- Check the throttle spindle and its bearings in the carburettor body for wear or scoring. Renew any parts as necessary.
- Refit the spindle to the body, ensuring that the fixed operating arm is in its correct position.
- Slide the throttle disc into its slot in the spindle until the two securing screws can be entered. Use two new screws.
- Manoeuvre the disc until it is a snug fit in the body with the throttle closed. Check the fit visually, and tighten the screws fully. Spread the split ends of the screws just sufficiently to prevent turning.

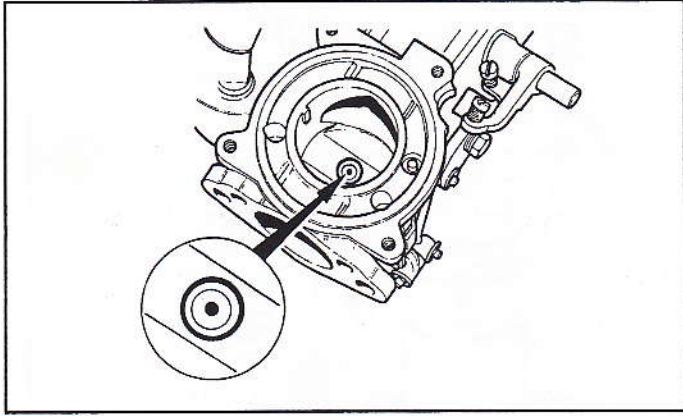

2

- Examine the gland packings for compression and wear. Check the jet for ovality and security of its fork. Renew any parts as necessary.
- Reassemble the jet assembly in the reverse order to its dismantling. Ensure that the washer is under the shoulder of the lower jet bearing, that the coned faces of the gland washers face towards the gland packing, and that the copper washer is fitted with its sharp edge towards the upper jet bearing.
- Refit the assembly to the carburettor body but leave the jet locking nut slack.
- When the jet is correctly centred (see illustration) it may appear offset from the centre of the jet bearing drilling.

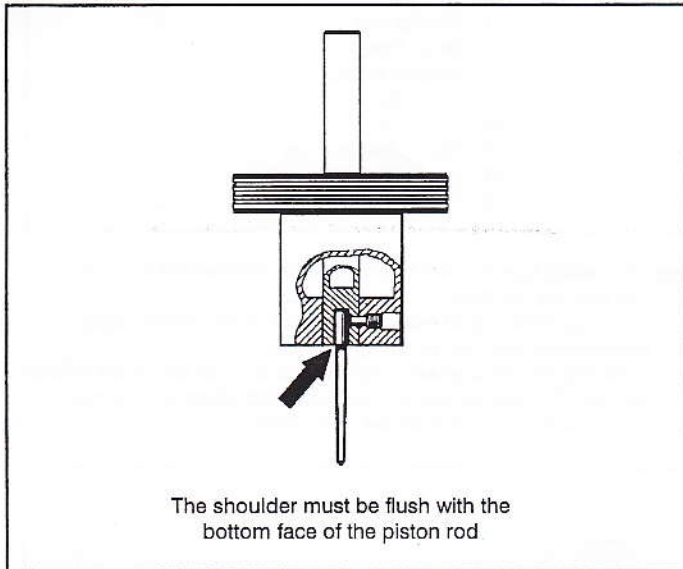

3

- Examine the piston assembly for damage to the piston rod and the outside surfaces of the piston. Check the piston key for security in the carburettor body. The piston must be scrupulously clean. Use either petrol or methylated spirits. Do not use abrasives.
- Examine the needle for damage or signs of wear. Refit the needle to the piston. The shoulder should be level with the face of the piston rod (see illustration). Fit and tighten the locking screw. Fit the piston assembly to the suction chamber, invert the complete assembly and spin the piston to check for concentricity of the needle.
- Refit the piston assembly to the carburettor body, taking care not to damage the needle.

- Replace the washer (when fitted) and piston spring in position over the piston rod.

4

- Clean inside the suction chamber and the piston rod guide using petrol or methylated spirit.
- Lightly oil the outside of the piston rod, and refit the suction chamber in its original position as marked on dismantling.
- Fit and tighten the securing screws.
- Centralize the jet.
- Refit the damper and washer. Do not fill with oil at this stage.

5

- Examine the float needle and seating; renew if faulty.
- Refit the seating to the float-chamber lid, taking care not to distort or overtighten. Put the needle into the seating, coned end first. Test for leakage with air pressure.
- Refit the hinged lever and hinge pin.
- Check the float level.

6

- Examine the float-chamber lid gasket; renew if necessary.
- Check the float for damage or puncturing; renew if necessary.
- Refit the float to the chamber. Fit the lid and gasket in its original position as marked. Replace the cover cap and nut or cover cap, stay, washer and nut; or drain pipe, washers and nut, as appropriate to the carburettor. Do not overtighten.
- Refit the float-chamber assembly to the carburettor body. Ensure that the fibre washers or rubber grommets are in good condition. Check that the washers are in their correct positions. Insert the rubber grommets in the float-chamber banjo and then push the bolt through them (when fitted).
- Insert the filter assembly, spring end first, and refit the banjo and bolt together with the fibre washers. Note that the recessed face of the banjo fits toward the hexagon end of the bolt.

Replacement of Spindles and Spindle Bushes

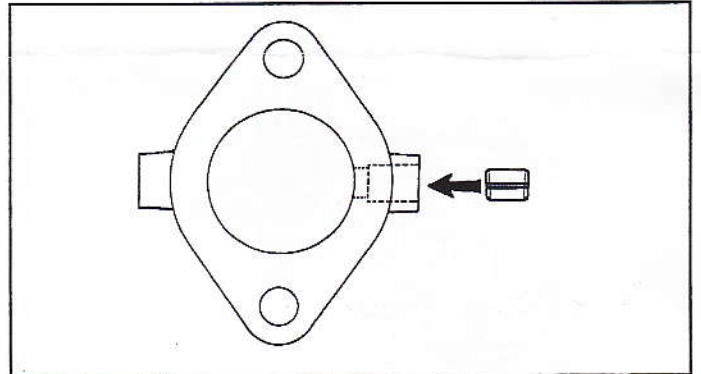

If new bushes are required, we recommend the fitment of the modern teflon-coated steel backed type as supplied in our kits.

The body needs to be bored out in line to 8mm (1/4" diameter spindle) or 9.5mm (5/16" diameter spindle). This is best achieved in a lathe. For best results, the depth of the bore should be limited to the length of the bush as shown in the diagram above, and not right through into the venturi. The bushes can then be pushed in until flush with the throttle body using special tool ABF 185.

On some SU types, the throttle stops and levers are held in place by a taper pin. The diagram below shows the clearances required on the H type. NOTE: The throttle disc must be held firmly closed when setting these clearances and whilst drilling the stops.

X = 1/8" (3.2mm)
Y = 0.015" (0.38mm)

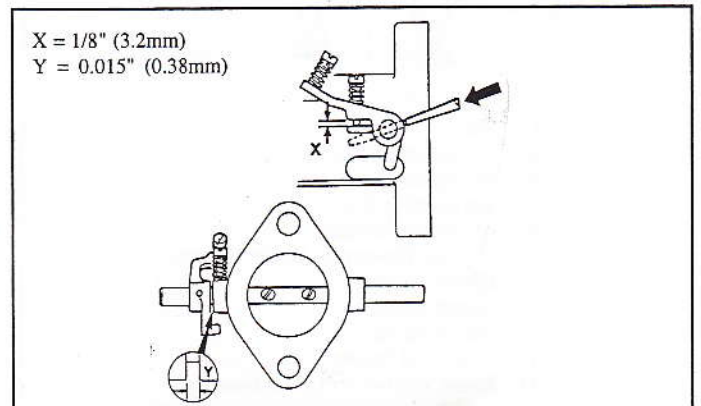

7

- (a) Refit the return spring plate, return spring and the return spring clip to the throttle spindle. Tension the spring by turning the clip on the spindle and tighten the clip pinch-bolt. Refit the operating lever, and tighten the clamping bolt.
- (b) Refit the linkage assembly; use new split pins. Ensure that the distance washer and double-coil spring washer are in their correct positions in relation to the fast-idle cam.

Tuning (Single Carburettors)

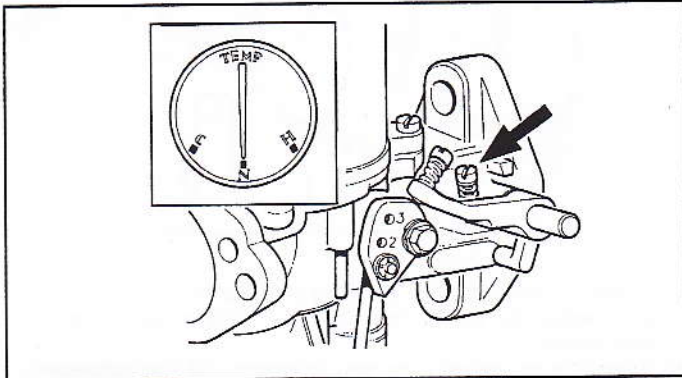

1

- (a) Warm engine up to normal temperature.
- (b) Switch off engine.
- (c) Unscrew the throttle adjusting screw until it is just clear of its stop and the throttle is closed.
- (d) Set throttle adjusting screw 1.5 turns open.

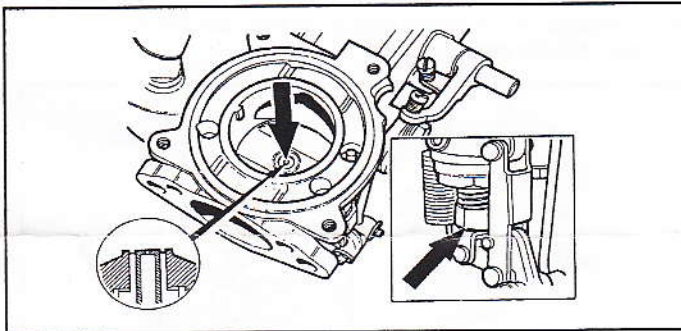

2

- (a) Mark parts for reassembly and remove piston/suction chamber unit.
- (b) Disconnect mixture control wire.
- (c) Screw the jet adjusting nut until the jet is flush with the bridge of the carburettor or fully up if this position cannot be obtained.

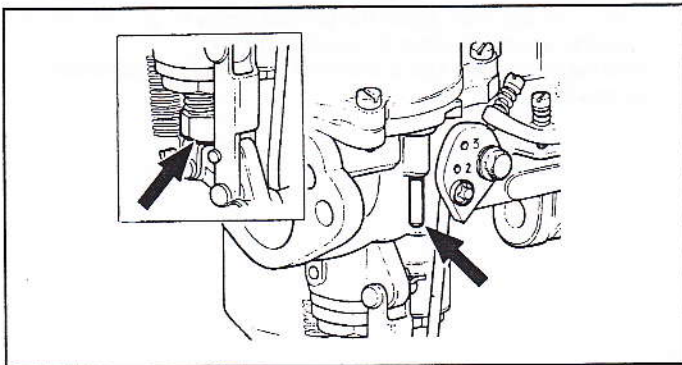

3

- (a) Replace the piston/suction chamber unit as marked.
- (b) Check that the piston falls freely onto the bridge when the lifting pin is released.
- (c) Turn down the jet adjusting nut 1.5 turns.

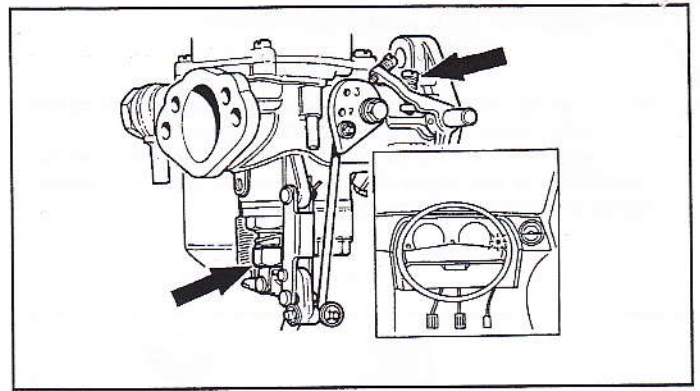

4

- (a) Restart the engine and adjust the throttle adjusting screw to give desired idling as indicated by the glow of the ignition warning light.
- (b) Turn the jet adjusting nut up to weaken or down to enrich until the fastest idling speed consistent with even running is obtained.
- (c) Re-adjust the throttle adjusting screw to give correct idling if necessary.

5

The effect of mixture strength on exhaust smoke

- A. TOO WEAK: Irregular note, splashy misfire, and colourless.
- B. CORRECT: Regular and even note.
- C. TOO RICH: Regular or rhythmical misfire, blackish.

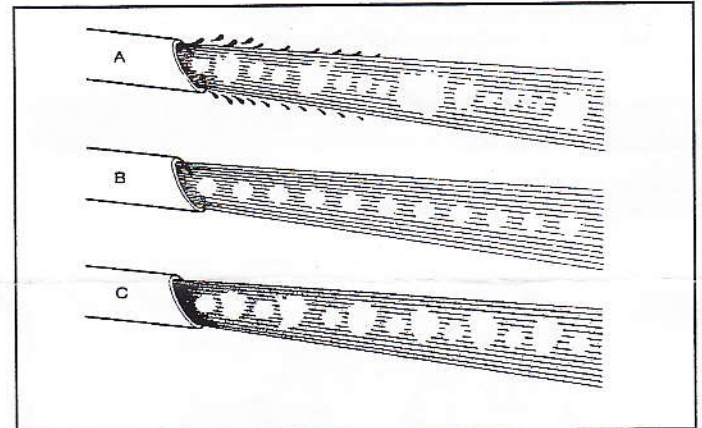

6

- (a) Check for correct mixture by gently pushing the lifting pin up about 0.8 mm (1/32 in).
- (b) The graph illustrates the effect on engine r.p.m. when the lifting pin raises the piston, indicating the mixture strength.

RICH MIXTURE: r.p.m. increase considerably.

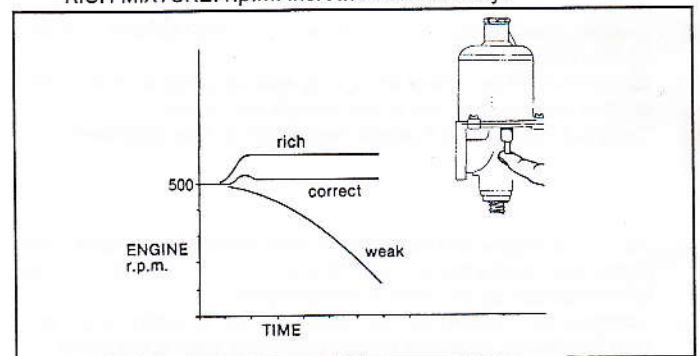

CORRECT MIXTURE: r.p.m. increase very slightly.

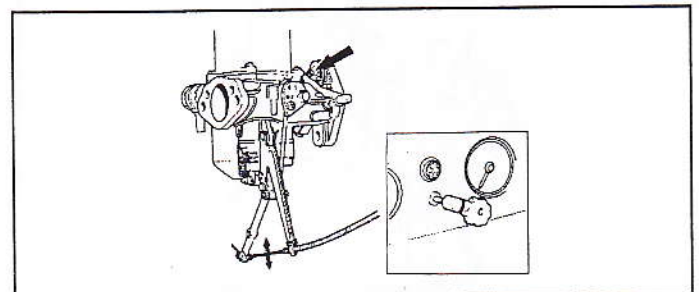

WEAK MIXTURE: r.p.m. immediately decrease.

- 7
- Reconnect the mixture control wire with about 1.6 mm (1/16 in) free movement before it starts to pull on the jet lever.
 - Pull the mixture control knob until the linkage is about to move the carburetter jet and adjust the fast-idle screw to give an engine speed of about 1,000 r.p.m. when hot.

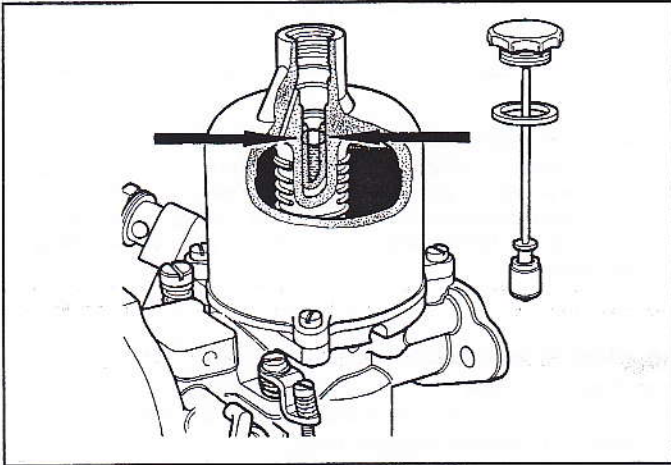

- 8
- Finally top up the piston damper with thin engine oil of grade S.A.E. 20 until the level is just below the top of the hollow piston rod.

Tuning (Multi-Carburetters)

Remove the air cleaners and carry out the instructions in item 1 (single units) on all carburetters then:

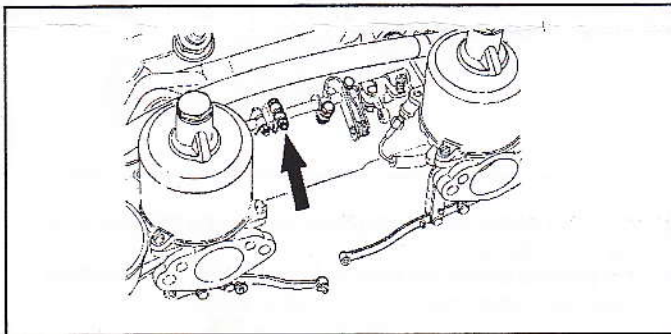

- 1
- Slacken one of the clamping bolts on the throttle spindle interconnections.
 - Disconnect the jet control linkage by removing one or, in the case of triple carburetters, two of the linkage swivel pins.
 - Carry out items 2 and 3 (single carburetters), then additionally:
- 2
- Restart the engine and adjust the throttle adjusting screws on each carburetter to give the desired idling speed of 500 to 600 r.p.m. as recommended by the vehicle manufacturer.
 - Compare the intensity of the intake 'hiss' on all carburetters and alter the throttle adjusting screws until each 'hiss' is the same.

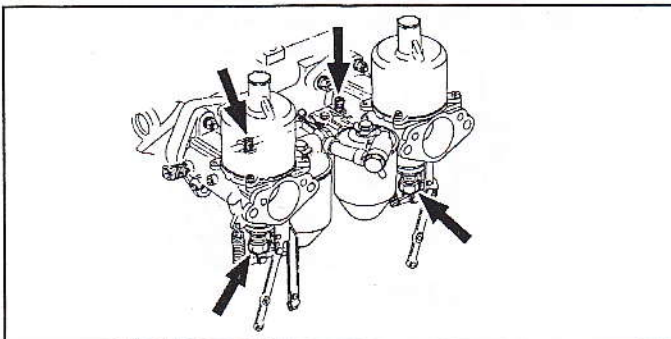

- 3
- Turn the jet adjusting nuts on all carburetters up to weaken or down to enrich the same amount until the fastest idling speed consistent with even running is obtained.
 - Re-adjust the throttle adjusting screws to give correct idling if necessary.

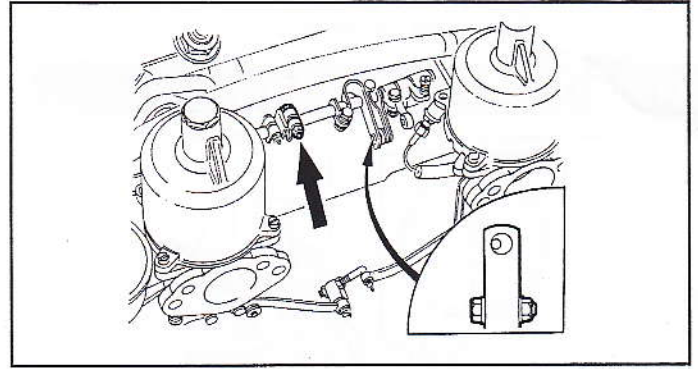

- 4
- Check for correct mixture by gently pushing the lifting pin of the front carburetter up 0.8 mm (1/32 in). (See section on single carburetters.)
 - Repeat the operation on the rear carburetter and after adjustment re-check the front carburetter since the two are interdependent.
- 5
- Tighten the clamp bolt of the throttle spindle interconnections and set the link pin lever with the pin resting against the edge of the pick-up lever hole (see inset). This provides the correct delay in opening the front carburetter throttle disc.
 - Re-connect the jet control linkage, so that both jets commence to move simultaneously.

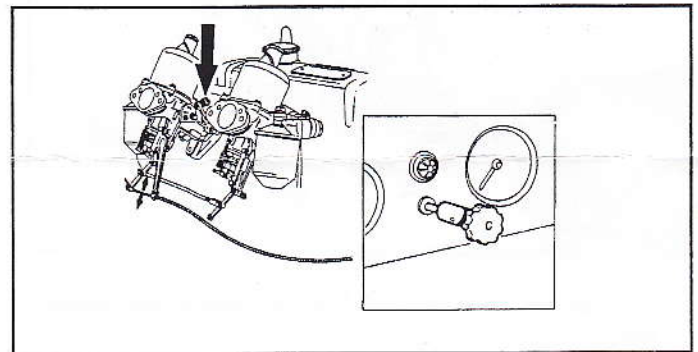

- 6
- Reconnect the mixture control wire with about 1.6 mm (1/16 in) free movement before it starts to pull on the jet levers.
 - Pull the mixture control knob until the linkage is about to move the carburetter jets, and adjust the fast-idle screw to give an engine speed of about 1,000 to 1,200 r.p.m. when hot.
 - Refit the air cleaners and re-check for correct mixture as described in item 4.

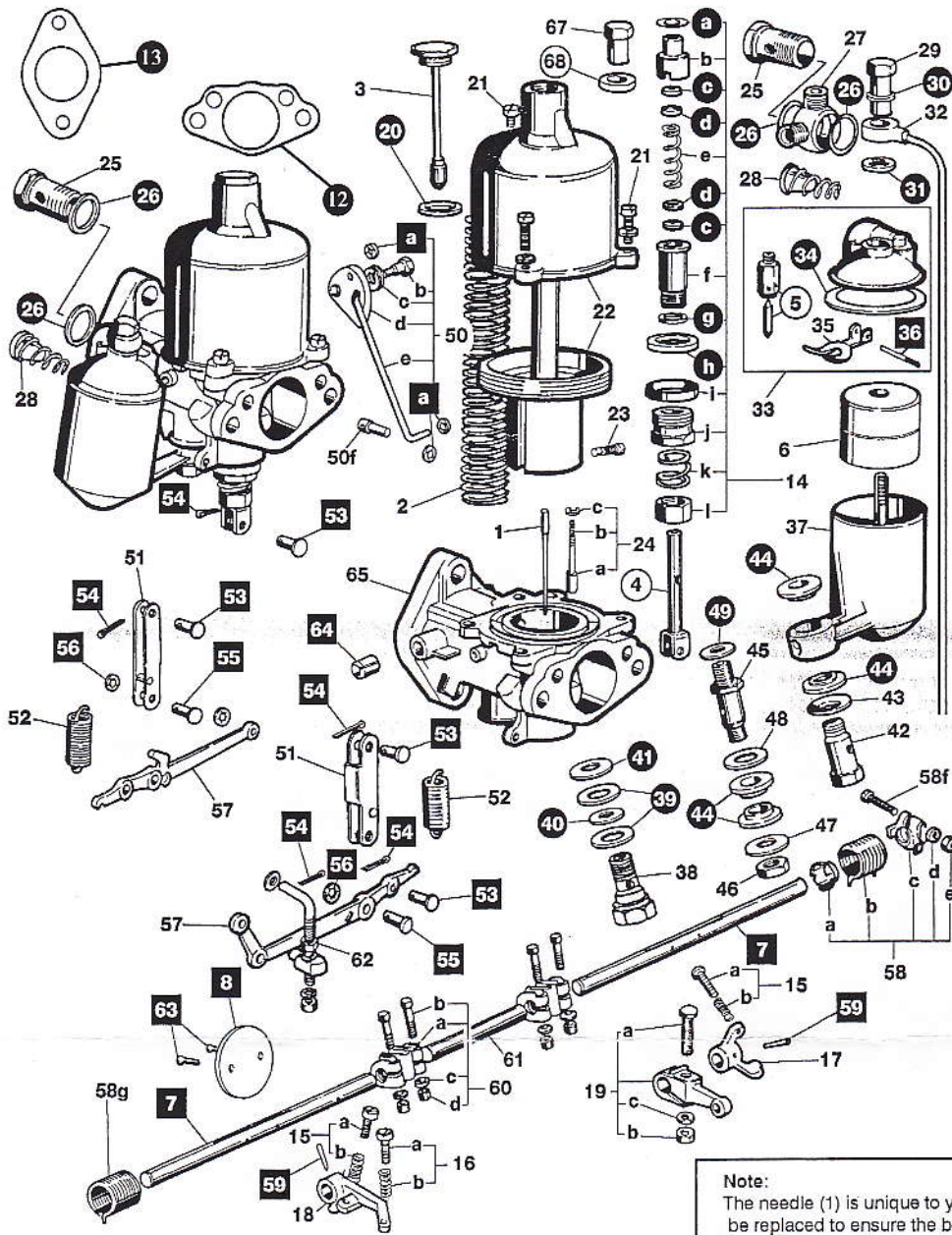

- Gasket Pack
- Service Kit (CSK) in addition to Gasket Pack
- Rebuild Kit (CRK) in addition to CSK

Each kit contains enough components to service one carburettor.
The pair of carburetters illustrated are H4 but most H types are similar.

Note:
The needle (1) is unique to your car and should be replaced to ensure the best results (see catalogue).
The spindle supplied may be longer than necessary and should be cut to length of original.
To ensure that the spindle bushes are a correct fit, great care must be taken to line/ream the body of the carburettor:

8mm - 1/4" diameter spindle
9.5mm - 5/16" diameter spindle

- | | | | |
|--|--|--|--|
| <ul style="list-style-type: none"> 1 Needle 2 Piston Spring 3 Damper 4 Jet Assembly 5 Needle and Seat Kit 6 Float Kit 7 Throttle Spindle Kit 8 Throttle Disc Kit 12 Gasket - Air Inlet 13 Gasket - Engine Flange 14 Jet Bearing Kit <ul style="list-style-type: none"> a Top Bearing Washer b Top Bearing c Cork Gland d Washer Gland e Spring f Bottom Bearing g Bottom Bearing Washer h Cork Gland i Sealing Ring j Jet Sealing Nut k Spring l Jet Adjusting Nut 15 Slow Run Screw Kit <ul style="list-style-type: none"> a Throttle Stop Adjusting Screw b Spring | <ul style="list-style-type: none"> 16 Fast Idle Screw Kit <ul style="list-style-type: none"> a Fast Idle Adjusting Screw b Spring 17 Throttle Stop 18 Fast Idle/Stop Lever 19 Throttle Lever <ul style="list-style-type: none"> a Bolt b Nut c Washer 20 Fibre Washer 21 Suction Chamber Screws 22 Suction Chamber - Piston Assy 23 Needle Lock Screw 24 Lift Pin Kit <ul style="list-style-type: none"> a Lift Pin b Spring c Circlip 25 Banjo Bolt 26 Banjo Washers 27 Banjo 28 Filter 29 Float Lid Bolt (long) see 67 30 Washer 31 Serrated Washer 32 Overflow Pipe 33 Float Lid Assembly 34 Float Lid Washer | <ul style="list-style-type: none"> 35 Float Lever 36 Float Lever Pin 37 Float Chamber 38 Holding Up Bolt 39 Fibre Washer 40 Brass Washer 41 Fibre Washer 42 Holding Up Bolt 43 Dished Washer 44 Rubber Grommet 45 Holding Up Stud 46 Nut 47 Steel Washer 48 Steel Washer 49 Fibre Washer 50 Fast Idle Cam Kit <ul style="list-style-type: none"> a Starlock Washer b Pivot Bolt c Spring Washer d Fast Idle Cam e Tension Link f Pivot Pin 51 Jet Link 52 Jet Return Spring 53 Pivot Pin see 55 54 Split Pin see 56 | <ul style="list-style-type: none"> 55 Pivot Pin alternative to 53 56 Starlock Washer use with 55 57 Jet Lever 58 Throttle Return Spring Kit <ul style="list-style-type: none"> a Spring Anchor b Left Hand Spring c Retaining Clip d Washer e Nut f Bolt g Right Hand Spring 59 Taper Pin 60 Coupling Assembly <ul style="list-style-type: none"> a Coupling b Bolt c Washer d Nut 61 Throttle Connecting Rod 62 Choke Connecting Link Assy 63 Disc Screw 64 Spindle Bush 65 Body 66 Ignition Union not shown 67 Float Lid Fixing Bolt (short) alternative 68 Cover Cap use with 67 |
|--|--|--|--|